



Product Technical Specification

AirPrime XM1110



SIERRA
WIRELESS®

41111059
Rev 1

Important Notice

Due to the nature of wireless communications, transmission and reception of data can never be guaranteed. Data may be delayed, corrupted (i.e., have errors) or be totally lost. Although significant delays or losses of data are rare when wireless devices such as the Sierra Wireless modem are used in a normal manner with a well-constructed network, the Sierra Wireless modem should not be used in situations where failure to transmit or receive data could result in damage of any kind to the user or any other party, including but not limited to personal injury, death, or loss of property. Sierra Wireless accepts no responsibility for damages of any kind resulting from delays or errors in data transmitted or received using the Sierra Wireless modem, or for failure of the Sierra Wireless modem to transmit or receive such data.

Safety and Hazards

Do not operate the Sierra Wireless modem in areas where blasting is in progress, where explosive atmospheres may be present, near medical equipment, near life support equipment, or any equipment which may be susceptible to any form of radio interference. In such areas, the Sierra Wireless modem **MUST BE POWERED OFF**. The Sierra Wireless modem can transmit signals that could interfere with this equipment.

Do not operate the Sierra Wireless modem in any aircraft, whether the aircraft is on the ground or in flight. In aircraft, the Sierra Wireless modem **MUST BE POWERED OFF**. When operating, the Sierra Wireless modem can transmit signals that could interfere with various onboard systems.

Note: Some airlines may permit the use of cellular phones while the aircraft is on the ground and the door is open. Sierra Wireless modems may be used at this time.

The driver or operator of any vehicle should not operate the Sierra Wireless modem while in control of a vehicle. Doing so will detract from the driver or operator's control and operation of that vehicle. In some states and provinces, operating such communications devices while in control of a vehicle is an offence.

Limitation of Liability

The information in this manual is subject to change without notice and does not represent a commitment on the part of Sierra Wireless. SIERRA WIRELESS AND ITS AFFILIATES SPECIFICALLY DISCLAIM LIABILITY FOR ANY AND ALL DIRECT, INDIRECT, SPECIAL, GENERAL, INCIDENTAL, CONSEQUENTIAL, PUNITIVE OR EXEMPLARY DAMAGES INCLUDING, BUT NOT LIMITED TO, LOSS OF PROFITS OR REVENUE OR ANTICIPATED PROFITS OR REVENUE ARISING OUT OF THE USE OR INABILITY TO USE ANY SIERRA WIRELESS PRODUCT, EVEN IF SIERRA WIRELESS AND/OR ITS AFFILIATES HAS BEEN ADVISED OF THE POSSIBILITY OF SUCH DAMAGES OR THEY ARE FORESEEABLE OR FOR CLAIMS BY ANY THIRD PARTY.

Notwithstanding the foregoing, in no event shall Sierra Wireless and/or its affiliates aggregate liability arising under or in connection with the Sierra Wireless product, regardless of the number of events, occurrences, or claims giving rise to liability, be in excess of the price paid by the purchaser for the Sierra Wireless product.

Patents

This product may contain technology developed by or for Sierra Wireless Inc. This product includes technology licensed from QUALCOMM®. This product is manufactured or sold by Sierra Wireless Inc. or its affiliates under one or more patents licensed from InterDigital Group and MMP Portfolio Licensing.

Copyright

© 2017 Sierra Wireless. All rights reserved.

Trademarks

Sierra Wireless®, AirPrime®, AirLink®, AirVantage® and the Sierra Wireless logo are registered trademarks of Sierra Wireless.

Windows® and Windows Vista® are registered trademarks of Microsoft Corporation.

Macintosh® and Mac OS X® are registered trademarks of Apple Inc., registered in the U.S. and other countries.

QUALCOMM® is a registered trademark of QUALCOMM Incorporated. Used under license.

Other trademarks are the property of their respective owners.

Contact Information

Sales information and technical support, including warranty and returns	Web: sierrawireless.com/company/contact-us/ Global toll-free number: 1-877-687-7795 6:00 am to 6:00 pm PST
Corporate and product information	Web: sierrawireless.com

Revision History

Revision number	Release date	Changes
1	June 23, 2017	Initial revision in SWI template.

>> Contents

Function Description	6
Overview	6
Potential Applications	6
Product Highlights and Features	7
System Block Diagram	8
Multi-tone Active Interference Canceller	8
1PPS	8
AGPS for faster TTFF (EPO in flash™)	8
EASY™	9
AlwaysLocate™	9
LOCUS	10
PPS sync NMEA	10
Specifications	11
Mechanical Dimensions	11
Recommended PCB Pad Layout	11
Pin Configuration	12
Pin Assignment	12
Description of I/O Pins	13
Specifications	15
Absolute Maximum Ranges	16
Operating Conditions	16
Protocols	17
NMEA Output Sentences	17
GGA—Time, Position and Related Data of Navigation Fix	17
GSA—GNSS DOP and Active Satellites, Including GPS(GPGSA) and GLONASS(GLGSA)	19
GSV— Satellites in View, Including GPS(GPGSV) and GLONASS(GLGSV)	20
RMC—Recommended Minimum Navigation Information	22
VTG—Course and Speed Information Relating to the Ground	23

MTK NMEA Command Protocols	24
Reference Design	25
Reference Schematic Design for Using the RTCM/I2C/SPI	25
Schematic Reference Design for the RTCM	25
Schematic Reference Design for Using I2C	26
Schematic Reference Design for the SPI Bus	27
Patch (Passive) Antenna	28
Active Antenna	29
Packing and Handling	30
Packaging and Handling (Tape Reel)	30
Storage and Floor Life Guidelines	31
Moisture Color Coded Card & Caution Label	31
Conditions for Pre-baking	32
Drying	33
ESD Handling	34
Reflow Soldering Temperature Profile	35
SMT Reflow Soldering Temperature Profile (For Reference Only)	35
Manual Soldering	38

>> 1: Function Description

Overview

The XM1110 is a GNSS (GPS + GLONASS) receiver; it is one of the smallest MediaTek-based modules in the world, for it has an ultra-compact size of 9.0 x 9.5 x 2.1 mm in a QFN Package. This ultra-compact module provides multiple interfaces such as I2C, SPI & UART, and its unique design of SMPS is capable of reducing power consumption to a great extent.

The XM1110 is built based on MediaTek's new generation GNSS Chipset MT3333. It supports up to 210 PRN channels with 99 search channels and 33 simultaneous tracking channels. With support of QZSS, SBAS (WAAS, EGNOS, MSAS), QZSS and AGPS, XM1110 can provide even more accurate positioning. Its *Tone Active Interference Canceller* is capable of removing 12 active noise sources, enabling more flexibility in system design.

The XM1110 is integrated along with power managements and many advanced features, including AlwaysLocate™, EASY™, EPO™, PPS sync NMEA and logger. It is ideally suitable for power sensitive devices especially in portable applications.

Potential Applications

- Handheld Devices
- M2M applications
- Asset management
- Surveillance systems
- Wearable products



Figure 1-1: XM1110

Product Highlights and Features

- 33 tracking/ 99 acquisition-channel GPS +GLONASS receiver
- Supports QZSS & SBAS(WAAS, EGNOS, MSAS, GAGAN)¹
- Sensitivity: -165dBm
- Update Rate: up to 10Hz²
- 12 multi-tone active interference canceller²
- High accuracy 1-PPS timing (± 20 ns RMS) and the pulse width is 100ms
- AGPS Support for Fast TTFF (EPO in flash™; choose from 7, 14, or 30 days)
- EASY™: Self-Generated Orbit Prediction for instant positioning fix³
- AlwaysLocate™ Intelligent Algorithm (Advance Power Periodic Mode) for power saving³
- PPS sync NMEA³
- LOCUS (Embedded Logger Function)
- Consumption current(@3.3V):
 - For GPS+GLONASS
 - Acquisition: 23mA/ 26mA /30mA (min / typical / max)
 - Full Power Tracking: 21mA / 23mA /28mA (min / typical / max)
 - GLP (GNSS low-power) Tracking: 7mA / 16mA / 32mA (min / typical / max)
- RoHS

-
1. GAGAN will be supported upon its starting date of service.
 2. SBAS can only be enabled when update rate is equal or less than to 5Hz.
 3. The features need customized firmware or command programming handled by customer. Please refer to our “PMTK Command List”.

System Block Diagram

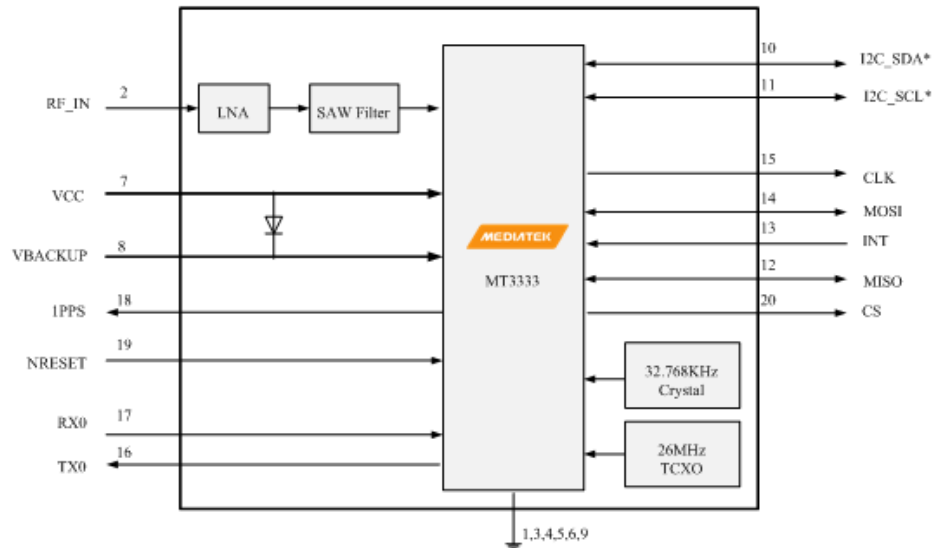

Figure 1-2: System Block Diagram. *I2C disabled in XM1110 by default, keep pin floating.

Multi-tone Active Interference Canceller

Navigation systems often integrate with variant applications that are not limited to Wi-Fi, GSM/GPRS, 3G/4G, Bluetooth. Such systems often generate RF harmonics which would influence the GPS reception and performance.

The embedded Multi-tone Active Interference Canceller (MTAIC) can reject unwanted RF harmonics of the nearby on-board active components. MTAIC improves the capacity of GPS reception, eliminating the need for hardware integration engineering to make hardware changes. The XM1110 cancels up to 12 independent channels continuous interference wave.

1PPS

The XM1110 generates a-pulse-per-second signal (1 PPS). It is an electrical signal which precisely indicates the start of a second with the accuracy of $\pm 20\text{ns}$ RMS (Root Mean Square). The PPS signal is provided through a designated output pin for many external applications. The pulse is not only limited to being active every second but is also allowed to set up the required duration, frequency, and active high/low through a programmable user-defined setting.

AGPS for faster TTFF (EPO in flash™)

The AGPS (EPO in flash™) provides predicated EPO (Extended Prediction Orbit) data to speed up TTFF (Time To First Fix). This feature is useful when a satellite signal is weak. AGPS can be downloaded from an FTP server via the Internet or

through a wireless network. The GPS engine in the module will apply EPO data to assist with position calculation when navigation information from satellites is insufficient. For more details on EPO, please contact us.

EASY™

EASY™ (Embedded Assist System) is for quick positioning/TTFB when information received from the satellites is insufficient (weak signal). When EASY™ is enabled, the GPS engine will automatically calculate and then predict single ephemeris up to three days. The predicted information will be saved into the memory and the GPS engine will then use the saved information for later positioning. Backup power (VBACKUP) is required for EASY™.

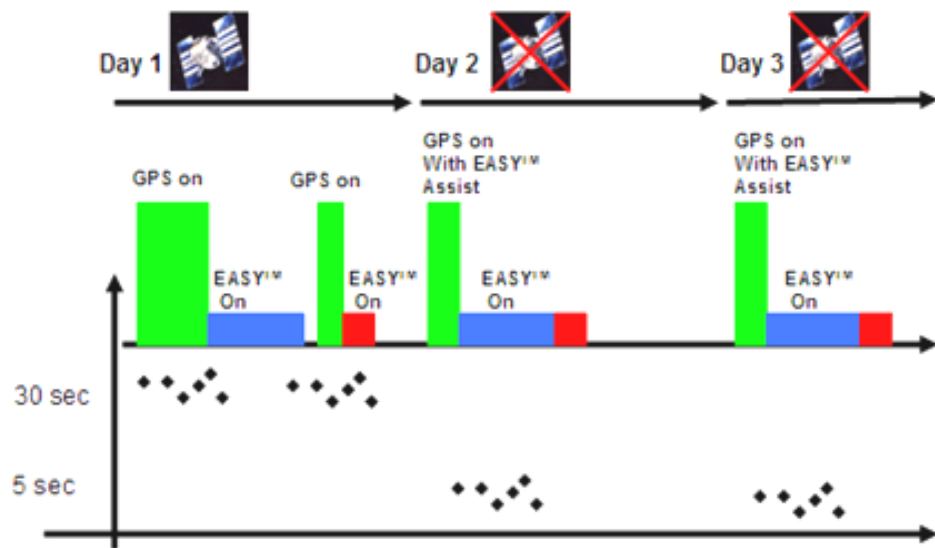

Figure 1-3: Operation of EASY™

When the module obtains information from GPS satellites, the GPS engine will start to pre-calculate and predict orbits automatically for three days.

AlwaysLocate™

In *AlwaysLocate™* mode, the on/off time can be adjusted adaptively to achieve balance between positioning accuracy and power consumption depending on environmental or motion conditions.

Figure 1-4 gives some insight on power saving in different cases when *AlwaysLocate™* mode is enabled. For command detail, please contact Sierra Wireless sales staff.

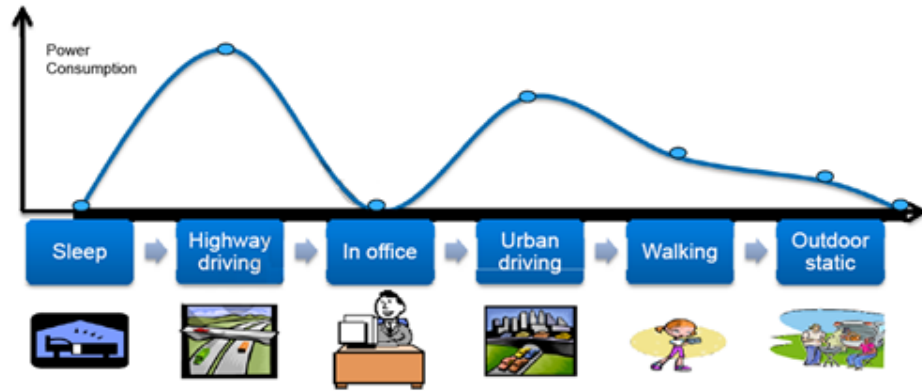

Figure 1-4: AlwaysLocatie

LOCUS

When LOCUS (Embedded Logger Function) is enabled, the receiver module will become a logger-capable device. It does not need any host or external flash data format such as UTC, latitude, longitude, valid or checksum for GPS data logging. The maximum log duration is up to two days under AlwaysLocate™.

PPS sync NMEA

Pulse-Per-Second (PPS) VS. NMEA can be used in the time service. The latency range of the beginning of UART Tx is between 465ms~485 ms at the MT3333 platform and behind the rising edge of PPS.

The PPS sync NMEA only supports 1Hz NMEA output and baud rate at 115200~14400 bps. For baud rates at 9600 bps and 4800 bps, only the RMC NMEA sentence is supported. If NMEA sentence outputs are supported even at the low baud rate, per-second transmission may exceed the threshold of one second.

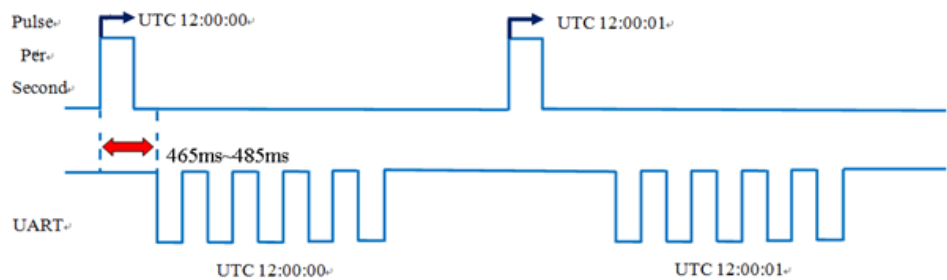

Figure 1-5: PPS sync NMEA

2: Specifications

Mechanical Dimensions

Dimension: (Unit: mm, Tolerance: +/- 0.2mm)

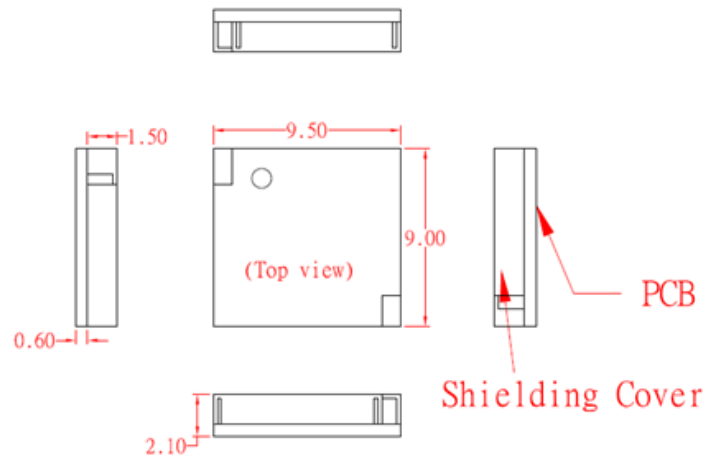

Figure 2-1: Mechanical Dimensions

Recommended PCB Pad Layout

(Unit: mm, Tolerance: 0.1mm)

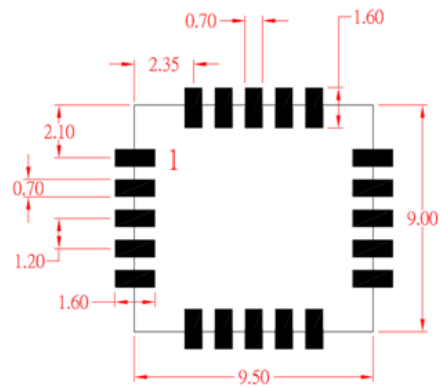

Figure 2-2: PCB Layout.

Pin Configuration

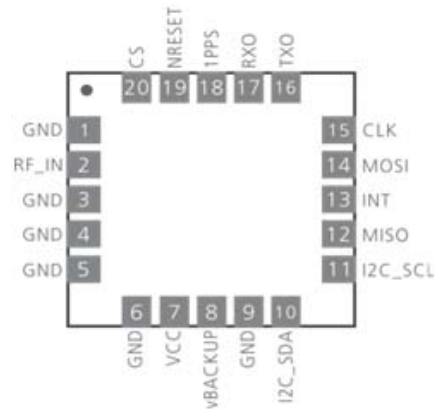

Figure 2-3: Pin Configuration. I2C_SCL and I2C_SDA pins are disabled by FW. Please keep them floating.

Pin Assignment

Table 2-1: Pin Assignment

Pin	Name	I/O	Description and Note
1	GND	P	Ground
2	RF_IN	I	GPS RF signal input
3	GND	P	Ground
4	GND	P	Ground
5	GND	P	Ground
6	GND	P	Ground
7	VCC	PI	Main DC power input
8	VBACKUP	PI	Backup power input for RTC & navigation data keep
9	GND	P	Ground
10	I2C_SDA ^a	I/O	I2C Serial data (in slave mode)
11	I2C_SCL ^a	I	I2C Serial clock (in slave mode)
12	MISO	O	SPI serial data output (in slave mode)
13	INT	O	Interrupt pin for SPI or I2C
14	MOSI	I	SPI serial data input (in slave mode)
15	CLK	I	SPI serial clock
16	TX0	O	Serial Data Output for NMEA output (TTL)
17	RX0	I	Serial Data Input for Firmware update (TTL)

Table 2-1: Pin Assignment

Pin	Name	I/O	Description and Note
18	1PPS	O	1PPS Time Mark Output 2.8V CMOS Level (Optional: pulse width can be customized) (Optional: customization definition)
19	NRESET	I	Reset Input, Low Active
20	CS	I	SPI serial chip select

a. Disabled by FW, please keep these pins floating.

Description of I/O Pins

- **Pin1:** GND (Ground)
- **Pin2:** RF_IN
 - The GPS RF signal input which can be connected to a passive antenna or an active antenna.
- **Pin3:** GND (Ground)
- **Pin4:** GND (Ground)
- **Pin5:** GND (Ground)
- **Pin6:** GND (Ground)
- **Pin7:** VCC
 - Main DC power supply (3.0V to 4.3V; typical: 3.3V). The ripple must be controlled under 50mVpp.
- **Pin8:** VBACKUP
 - This connects to the backup power of the GNSS module. A power source (such as a battery) connected to this pin will help the GNSS chipset in keeping its internal RTC running when the main power source is turned off. The voltage ranges from 2.0V~4.3V (typical: 3.0V).
 - If VBACKUP power is not reserved, the GNSS module will perform a lengthy cold start each time whenever it is powered on, as previous satellite information is not retained and needs to be re-transmitted.
 - If not used, keeps this pin floating.
- **Pin9:** GND (Ground)
- **Pin10:** I²C_SDA¹ (I²C; outputs GPS information/RTCM_TX)
- **Pin11:** I²C_SCL¹ (RTCM_RX)
 - This pin can be modified through firmware customization.
 - The *default* of this pin is defined to I²C_SCL. It will receive the clock for I²C application.
 - If the pin is customized to RTCM, it will receive DGPS data of RTCM protocol (TTL level).
 - If not used, keeps this pin floating.
- **Pin12:** MISO (SPI; outputs GPS information)
- **Pin13:** INT
 - This is the interrupt sync pin of the module. It is used to determine whether NMEA is stored in SPI/ I²C¹ buffer.
 - If NMEA data is ready and stored in SPI/ I²C¹ buffer, the pin will pull low.

1. Disabled by FW, please keep these pins floating.

- After entire NMEA packet of one second is read, the pin will pull high.
- **Pin14:** MOSI (SPI; to receive commands from system)
- **Pin15:** CLK (SPI; to receive clock time from system)
- **Pin16:** TX0 (UART 0 transmitter; outputs GPS information for application)
- **Pin17:** RX0 (UART 0 receiver; to receive commands from system)
- **Pin18:** 1PPS
 - This pin provides one pulse-per-second signal output. If not used, keeps this pin floating.
- **Pin19:** NRESET
 - **Active** on Low for the module to reset. If not used, keep this pin floating.

Table 2-2: NRESET

NRESET Level	Min(V)	Typ(V)	Max(V)
Low	0	0	1.5
High	2	2.8	3.3

- **Pin20:** CS (SPI; to select chip for system)
 - Active on Low to enable SPI

Specifications

Table 2-3: Specification Data

Description	
GNSS Solution	MTK MT3333 ^a
Frequency	GPS L1, 1575.42MHz GLONASS L1, 1598.0625~1605.375MHz
Sensitivity (GPS portion)	Acquisition: -148dBm, cold start Reacquisition: -163dBm, Hot start Tracking: -165dBm
SV Number GPS GLONASS	#1~32 #65~96 (see Chapter 3 for details)
TTFF (GPS, No. of SVs>4, C/ N>40dB, PDop<1.5)	Hot start: 1 second typical Warm start: 33 seconds typical Cold start: 35 seconds typical, 60 seconds Max
Position Accuracy	Without aid:3m (50% CEP) DGPS(SBAS(WAAS,EGNOS,MSAS, GAGAN ^b)):2.5m (50% CEP)
Velocity Accuracy	Without aid : 0.1m/s DGPS(SBAS(WAAS,EGNOS,MSAS, GAGAN ^b)):0.05m/s
Timing Accuracy (1PPS Output)	Default: ±20ns RMS within 100ms in one pulse (pulse width/duration can be customized)
Altitude	10,000m maximum (Normal mode: car/pedestrian/ aviation) 80,000m maximum (Balloon mode)
Velocity	Maximum 515m/s (1000 knots) ^c
Acceleration	Maximum 4G
Update Rate	1Hz (default), maximum 10Hz
Baud Rate	9600 bps (default)
DGPS	SBAS(default) [WAAS, EGNOS, MSAS, GAGAN ^b]
Power Supply	VCC: 3V to 4.3V; VBACKUP: 2.0V to 4.3V
Current Consumption @ 3.3V,1Hz Update Rate	GPS+GLONASS: Acquisition: 23mA/ 26mA /30mA (min / typical / max) Full Power Tracking: 21mA / 23mA /28mA (min / typical / max) GLP (GNSS low-power) Tracking : 7mA / 16mA / 32mA (min / typical / max)
Backup Power Consumption@ 3V	15uA (TYP)
Power Saving (Periodic)	Backup mode: 9uA(TYP) ^d Standby mode: 350uA(TYP) ^d
NRESET Current @ 3.3V	8mA(TYP)
Working Temperature	-40 °C to +85 °C

Table 2-3: Specification Data

Description	
Dimension	9.0x9.5 x 2.1 mm, SMD
Weight	0.4g

- a. RTCM is not enabled on this product
- b. GAGAN will be supported
- c. The number was simulated from lab test
- d. Please refer to PMTK 161 / 225

Absolute Maximum Ranges

Table 2-4: Maximum Ranges

	Symbol	Min.	Typ.	Max.	Unit
Power Supply Voltage	VCC	3.0	3.3	4.3	V
Backup Battery Voltage	VBACKUP	2.0	3.0	4.3	V

Operating Conditions

Table 2-5: Operating Conditions

	Condition	Min.	Typ.	Max.	Unit
Operation Supply Ripple Voltage	-	-	-	50	mVpp
RX0 TTL H Level	-	2.0	-	3.3	V
RX0 TTL L Level	-	0	-	0.8	V
TX0 TTL H Level	-	2.4	-	2.8	V
TX0 TTL L Level	-	0	-	0.4	V

>> 3: Protocols

NMEA Output Sentences

Table 3-1 lists all NMEA output sentences specifically developed and defined by MTK for MTK's products.

Table 3-1: Position Fix Indicator

Option	Description
GGA	Time, position and fix type data.
GSA	GNSS receiver operating mode, active satellites used in the position solution and DOP values.
GSV	The number of GPS satellites in view, satellite ID numbers, elevation, azimuth, and SNR values.
RMC	Time, date, position, course and speed data. The recommended minimum navigation information.
VTG	Course and speed information relative to the ground.

Table 3-2 lists NMEA output sentences used in GPS system and GLONASS system

Table 3-2: NMEA Output Sentence for GPS and GNSS

System	GGA	GSA	GSV	RMC	VTG
GPS	GPGGA	GPGSA	GPGSV	GPRMC	GPVTG
GNSS (GPS+GLONASS)	GNGGA	GPGSA GLGSA	GPGSV GLGSV ^a	GNRMC	GNVTG

a. In Talker ID, GP is a short term of "GPS"; GL is "GLONASS" and GN is "GPS +GLONASS"

GGA—Time, Position and Related Data of Navigation Fix

Table 3-3 explains the NMEA sentence below:

```
$GNGGA, 064951.000, 2307.1256, N, 12016.4438, E, 1, 8, 0.95, 39.9, M, 17.8, M, *65
```

Table 3-3: GGA Data Format

Name	Example	Units	Description
Message ID	\$GNGGA		GGA protocol header
UTC Time	064951.00 0		hhmmss.sss
Latitude	2307.1256		ddmm.mmmm

Table 3-3: GGA Data Format

Name	Example	Units	Description
N/S Indicator	N		N North or S South
Longitude	12016.443 8		dddmm.mmmm
E/W Indicator	E		E East or W West
Position Fix Indicator	1		See Table 3-4
Satellites Used	8		
HDOP	0.95		Horizontal Dilution of Precision
MSL Altitude	39.9	meters	Antenna Altitude above/below mean-sea-level
Units	M	meters	Units of antenna altitude
Geoidal Separation	17.8	meters	
Units	M	meters	Units of geoids separation
Age of Diff. Corr.		second	Null fields when DGPS is not used
Checksum	*65		
<CR> <LF>			End of message termination

Table 3-4: Position Fix Indicator

Value	Description
0	Fix not available
1	GPS Fix
2	Differential GPS Fix

*Note: when inputting the command \$PMTK353,0,1,0,0,0*2A, \$GNGGA will change to \$GLGGA (For GLONASS). When inputting the command \$PMTK353,1,0,0,0,0*2A, \$GNGGA will change to \$GPGGA (For GPS).*

GSA—GNSS DOP and Active Satellites, Including GPS(GPGSA) and GLONASS(GLGSA)

Table 3-5 explains the example NMEA sentence below:

```
GPS satellite system:
$GPGSA,A,3,29,21,26,15,18,09,06,10,,,,,2.32,0.95,2.11*00

GPS+GLONASS satellite system:
$GPGSA,A,3,08,28,20,04,32,17,11,,,,,1.00,0.63,0.77*1B (GPS
satellite)
$GLGSA,A,3,77,76,86,78,65,88,87,71,72,,,,,1.00,0.63,0.77*17
(GLONASS satellite)
```

Table 3-5: GGA Data Format

Name	Example	Units	Description
Message ID	\$GPGSA, or \$GLGSA		GSA protocol header
Mode 1	A		See Table 3-6
Mode 2	3		See Table 3-7
Satellite Used ^a	8		SV on Channel 1
Satellite Used	28		SV on Channel 2
....
Satellite Used			SV on Channel 12
PDOP	1		Position Dilution of Precision
HDOP	0.63		Horizontal Dilution of Precision
VDOP	0.77		Vertical Dilution of Precision
Checksum	*1B		
<CR> <LF>			End of message termination

a. GPS SV No. #01~#32
GLONASS SV No. #65~#96

Table 3-6: Mode 1

Value	Description
M	Manual—forced to operate in 2D or 3D mode
A	2D Automatic—allowing to switch to 2D/3D mode automatically

Table 3-7: Mode 2

Value	Description
1	Fix not available
2	2D (<4 SVs used)
3	3D (>=4 SVs used)

GSV— Satellites in View, Including GPS(GPGSV) and GLONASS(GLGSV)

Table 3-8 explains the example NMEA sentences below:

```
$GPGSV,4,1,14,28,75,321,44,42,54,137,39,20,53,080,44,17,40,30,44*77
$GPGSV,4,2,14,04,33,253,43,32,28,055,41,08,26,212,40,11,14,055,33*7F
$GPGSV,4,3,14,10,12,198,,07,06,179,38,23,04,125,44,27,02,314,*7E
$GPGSV,4,4,14,193,,,42,01,,,36*45
```

Table 3-8: GPGSV Data Format

Name	Example	Units	Description
Message ID	\$GPGSV		GSV protocol header
Number of Messages	4		(Depending on the number of satellites tracked, multiple messages of GSV data may be required) ^a
Message Number	1		
Satellites in View	14		
Satellite ID	28		Channel 1 (Range 1 to 32)
Elevation	75	degrees	Channel 1 (Maximum 90)
Azimuth	321	degrees	Channel 1 (True, Range 0 to 359)
SNR (C/No)	44	dB-Hz	Range 0 to 99, (null when not tracking)
....
Satellite ID	17		Channel 4 (Range 1 to 32)
Elevation	40	degrees	Channel 4 (Maximum 90)
Azimuth	330	degrees	Channel 4 (True, Range 0 to 359)
SNR (C/No)	44	dB-Hz	Range 0 to 99, (null when not tracking)

Table 3-8: GPGSV Data Format

Name	Example	Units	Description
Checksum	*77		
<CR> <LF>			End of message termination

a. One GSV sentence can only receive up to 4 SVs

Table 3-9 explains the example NMEA sentences below:

\$GLGSV,4,1,15,72,45,084,40,77,39,246,44,87,36,014,44,65,33,157,36*62

\$GLGSV,4,2,15,78,26,306,41,88,23,315,42,76,15,192,38,86,13,067,38*64

\$GLGSV,4,3,15,71,12,035,38*54

Table 3-9: GLGSV Data Format

Name	Example	Units	Description
Message ID	\$GLGSV		GSV protocol header
Number of Messages	4		(Depending on the number of satellites tracked, multiple messages of GSV data may be required) ^a
Message Number	1		
Satellites in View	15		
Satellite ID	72		Channel 1 (Range 1 to 32)
Elevation	45	degrees	Channel 1 (Maximum 90)
Azimuth	84	degrees	Channel 1 (True, Range 0 to 359)
SNR (C/No)	40	dB-Hz	Range 0 to 99, (null when not tracking)
....
Satellite ID	44		Channel 4 (Range 1 to 32)
Elevation	65	degrees	Channel 4 (Maximum 90)
Azimuth	157	degrees	Channel 4 (True, Range 0 to 359)
SNR (C/No)	36	dB-Hz	Range 0 to 99, (null when not tracking)
Checksum	*62		
<CR> <LF>			End of message termination

a. One GSV sentence can only receive up to 4 SVs

RMC—Recommended Minimum Navigation Information

Table 3-10 explains the example NMEA sentence below:

```
$GNRMC,064951.000,A,2307.1256,N,12016.4438,E,0.03,165.48,260406,3.05,W,A*2C
```

Table 3-10: RMC Data Format

Name	Example	Units	Description
Message ID	\$GNRMC		RMC protocol header
UTC Time	064951.000		hhmmss.sss
Status	A		A: data valid V: data not valid
Latitude	2307.1256		ddmm.mmmm
N/S Indicator	N		N: North S: South
Longitude	12016.4438		dddmm.mmmm
E/W Indicator	E		E: East W: West
Speed over Ground	0.03	Knots/hr	
Course over Ground	165.48	degrees	TRUE
Date	260406		ddmmyy
Magnetic Variation	3.05, W	degrees	E: East W: West (By Customization)
Mode	A		A: Autonomous mode D: Differential mode E: Estimated mode
Checksum	*2C		
<CR> <LF>			End of message termination
Message ID	\$GNRMC		RMC protocol header

Note: when inputting the command \$PMTK353,0,1,0,0,0*2A , \$GNRMC will change to \$GLRMC (for GLONASS). When inputting the command \$PMTK353,1,0,0,0,0*2A : \$GNRMC will change to \$GPRMC (for GPS).

VTG—Course and Speed Information Relating to the Ground

Table 3-11 explains the example NMEA sentence below:

```
$GNVTG,165.48,T,,M,0.03,N,0.06,K,A*37
```

Table 3-11: VTG Data Format

Name	Example	Units	Description
Message ID	\$GNVTG		VTG protocol header
Course	165.48	degrees	Measured heading
Reference	T		TRUE
Course		degrees	Measured heading
Reference	M		Magnetic Variation (By Customization)
Speed	0.03	Knots/hr	Measured horizontal speed
Units	N		Knots
Speed	0.06	km/hr	Measured horizontal speed
Units	K		Kilometers per hour
Mode	A		A: Autonomous mode D: Differential mode E: Estimated mode
Checksum	*37		
<CR> <LF>			End of message termination

Note: when inputting the command \$PMTK353,0,1,0,0,0*2A , \$GNVTG will change to \$GLVTG(For GLONASS). When inputting the command \$PMTK353,1,0,0,0,0*2A : \$GNVTG will change to \$GPVTG (For GPS).

MTK NMEA Command Protocols

Packet Type: 103 PMTK_CMD_COLD_START

Packet Meaning: Cold Start --- Discarding the data of Time, Position, Almanacs and Ephemeris at re-start.

Example: \$PMTK103*30<CR><LF>

4: Reference Design

This section introduces the reference schematic design for best performance. Additional tips and cautions on design are well documented in the related Application Note that is available upon request.

Reference Schematic Design for Using the RTCM/I²C/SPI

The XM1110 provides several interfaces to process GNSS NMEA data (by specified firmware):

1. UART0¹ + RTCM (for DGPS data)
2. UART0¹ + I²C (for NMEA data)
3. UART0¹ + SPI (for NMEA data)

Schematic Reference Design for the RTCM

Figure 4-1 provides a schematic reference design for the RTCM:

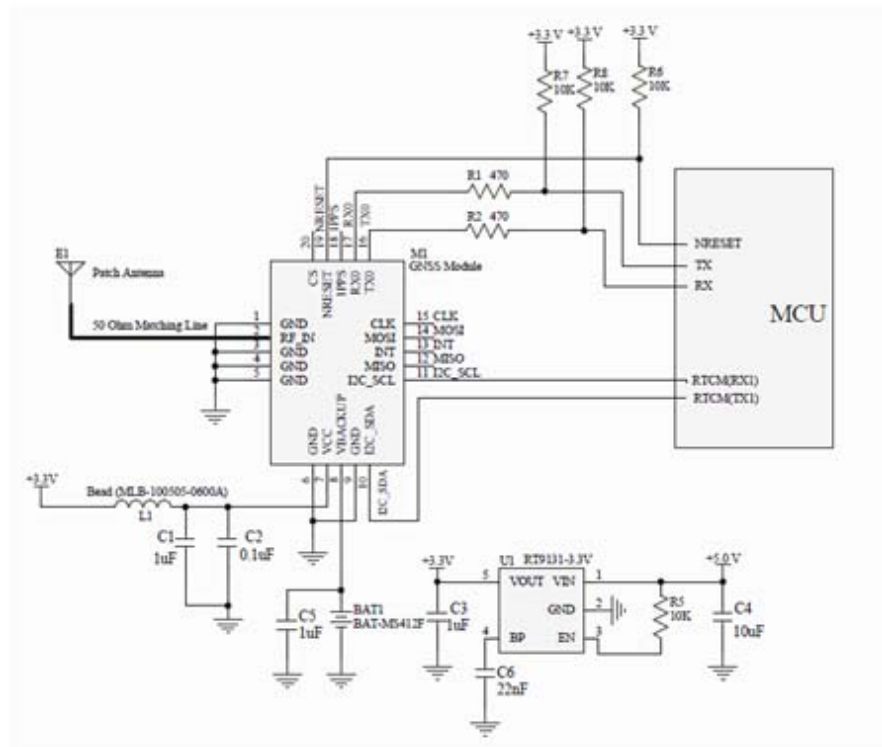

Figure 4-1: UART + RTCM

1. RTCM and I²C not supported on XM1110

4. Pull high resistors, R3 and R4, can be modified based on system application for I²C.
5. If you need more support and information on antenna implementation, please contact Sales.

Schematic Reference Design for the SPI Bus

Figure 4-3 provides a schematic reference design for the SPI bus:

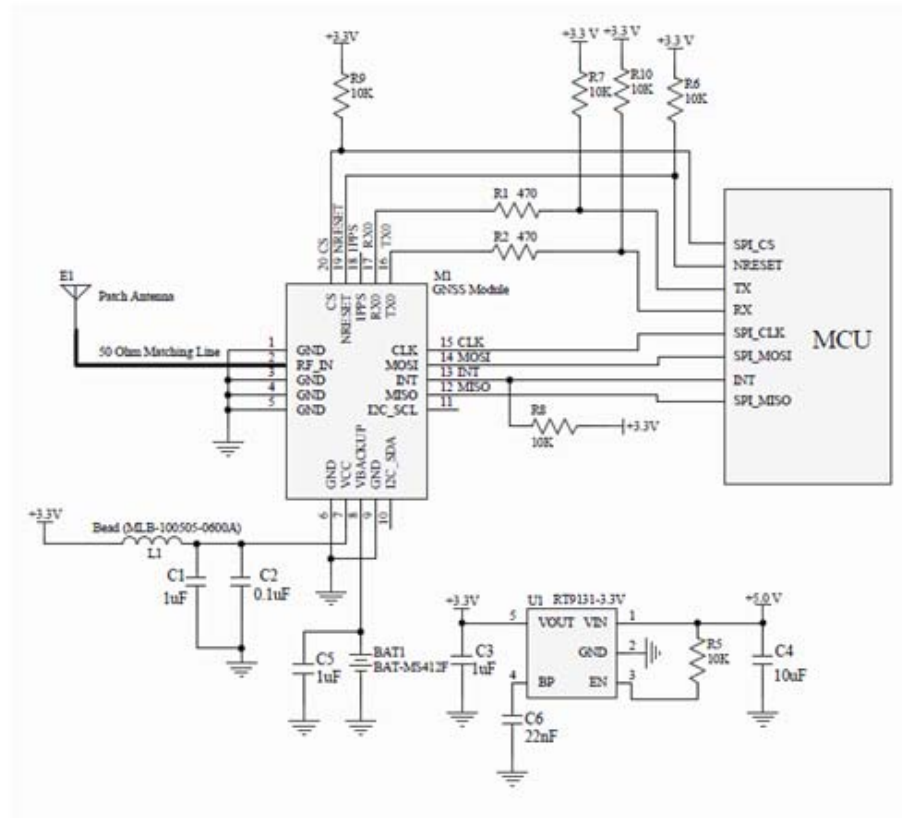

Figure 4-3: UART+SPI Application

Notes:

1. Ferrite bead L1 is added for power noise reduction. Use one with an equivalent impedance (600Ω at 100MHz; IDC 200mA).
2. Place C1, C2 and C5 bypass-capacitors as close as possible to the module.
3. Damping resistors, R1 and R2, can be modified based on system application for EMI.
4. If you need more support and information on antenna implementation, please contact Sales.

Patch (Passive) Antenna

Connect the passive antenna directly to RF_IN (Pin 2).

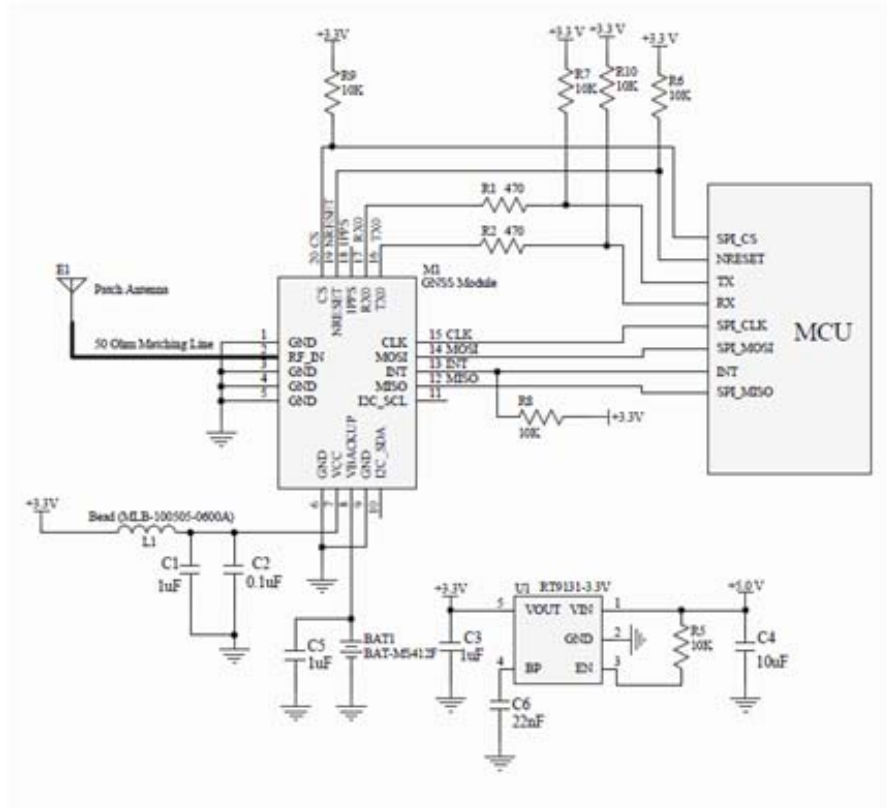

Figure 4-4: Patch Antenna

Notes:

1. Ferrite bead L1 is added for power noise reduction. Use one with an equivalent impedance (600Ω at 100MHz; IDC 200mA).
2. Place C1, C2 and C5 bypass-capacitors as close as possible to the module.
3. Damping resistors, R1 and R2, can be modified based on system application for EMI.
4. If you need more support and information on antenna implementation, please contact Sales.

Active Antenna

Please connect the external antenna to RF_IN (Pin2)

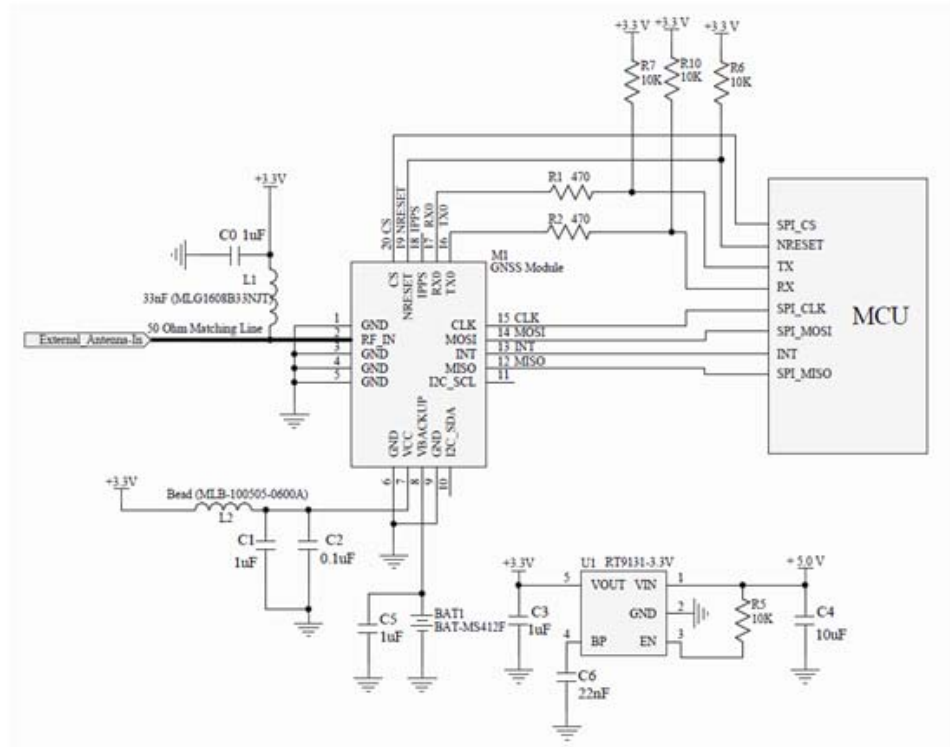

Figure 4-5: Active Antenna Application

Notes:

1. Ferrite bead L1 is added for power noise reduction. Use one with an equivalent impedance (600Ω at 100MHz; IDC 200mA).
2. Place C1, C2 and C5 bypass-capacitors as close as possible to the module.
3. Damping resistors R1 and R2 can be modified based on system application for EMI.
4. If you need more support and information on antenna implementation, please contact Sales.

5: Packing and Handling

The XM1110, like any other SMD device, is sensitive to moisture, electrostatic discharge and temperature. By following the standards of storage and handling outlined in this document for Sierra Wireless' modules, the chances of them being damaged during production setup can be reduced. This section will walk you through the basics on how Sierra Wireless packages the modules, to ensure that the modules arrive at their destination without any damages or deterioration for performance quality. Cautionary steps prior to the surface mount process are also included in the cautionary notes.

Important: Please read the following sections carefully to avoid possible damage.

Important: GPS/GNSS receiver modules are highly electrostatic-sensitive devices. Without ESD protections or without proper handling may lead to permanent damage to the modules.

Packaging and Handling (Tape Reel)

1500pcs/Reel

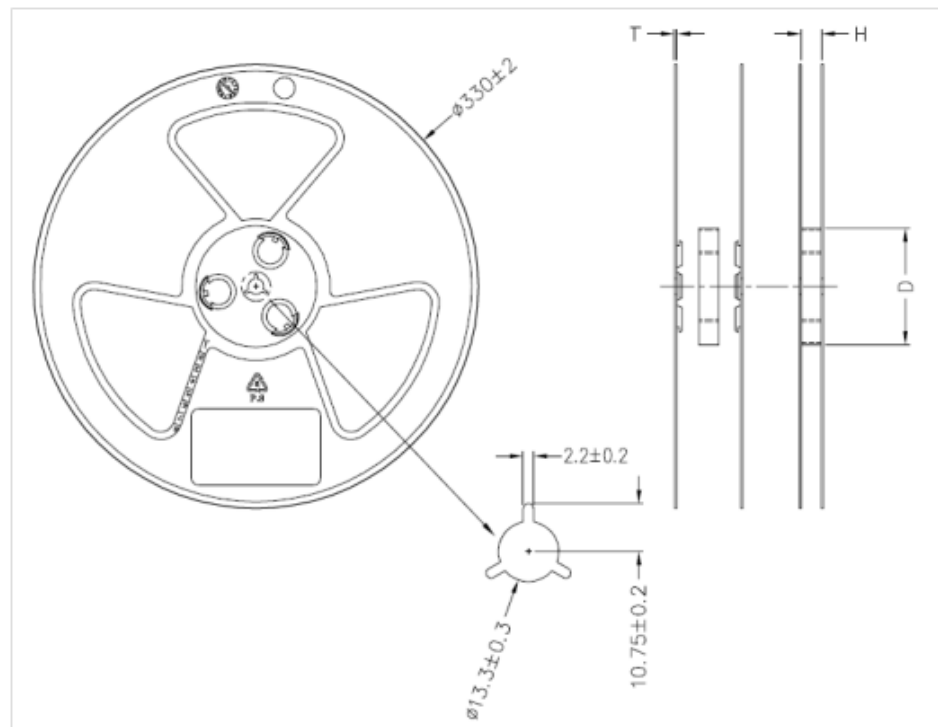

Figure 5-1: Reel Dimensions

Specs:H: 24.5 ± 1.5 ,T: 2.2 ± 0.2 ,D: 99 ± 1.5 **Note:** 13" Reel;**Material:** P.S**Unit:** (mm)

Figure 5-2: Tape Dimensions

Specs:Ao 10 ± 0.10 Bo 10.5 ± 0.10 Ko 2.4 ± 0.10 **Unit:** (mm)

Storage and Floor Life Guidelines

Moisture Color Coded Card & Caution Label

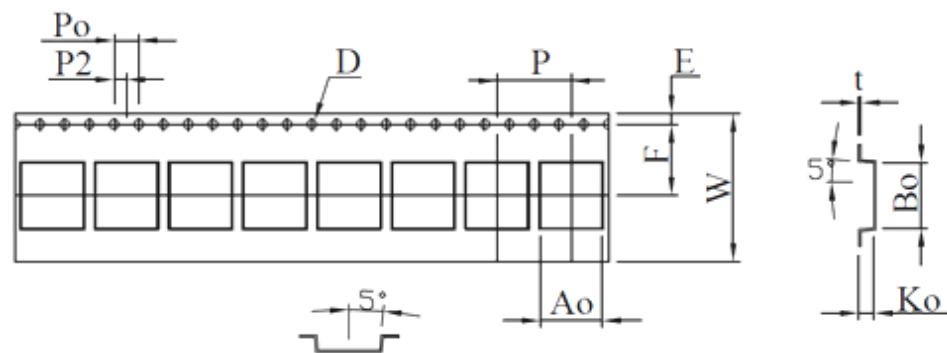
The moisture color-coded card provides an insight to the relative humidity in percentage (RH). When the GNSS modules are taken out, the RH level for the modules would be around or lower than 30%. A caution label is also included with each electrostatic bag.

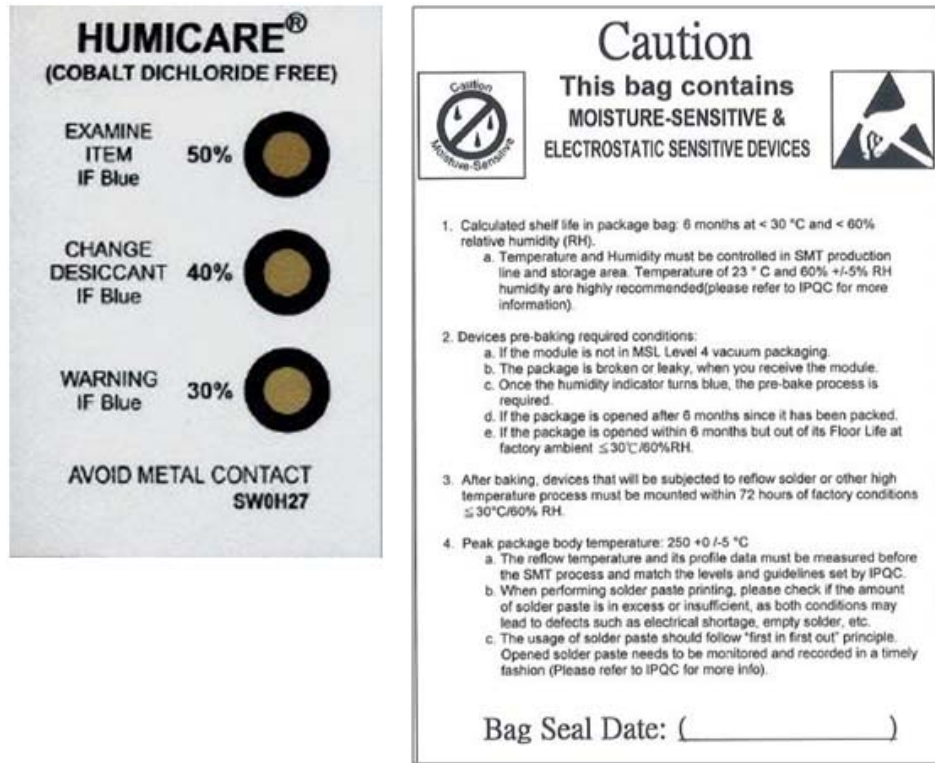

Figure 5-3: Moisture Color Coded Card and Caution Label

Sierra Wireless modules are moisture sensitive. If the package of modules has been stored under the condition of a non-condensing storage environment (<30°C; RH 60%) over 6 months, the modules will need to go through solder-reflow before SMT.

Important: Prior to solder-reflow, pre-baking will be mandatory if the modules meet any of the conditions listed below in “[Conditions for Pre-baking](#)”.

Conditions for Pre-baking

Pre-baking will necessary before the modules go through the solder-reflow process, if any condition listed below is met:

- The package of the module is broken or leaky when you receive it.
- When the humidity indicator turns blue.
- The package is opened six months after the module was packaged.
- The package is opened within six months but its Floor Life at factory ambient is affected (<=30°C; RH 60%).
- When the MSL (Moisture Sensivity Level) of vacuumed module package is higher than Level 4 (level 1~4 are safe; please refer to the [Figure 5-4](#) below):

LEVEL	FLOOR LIFE		SOAK REQUIREMENTS				
			STANDARD		ACCELERATED EQUIVALENT ¹		
					eV 0.40-0.48	eV 0.30-0.39	CONDITION
TIME	CONDITION	TIME (hours)	CONDITION	TIME (hours)	TIME (hours)	CONDITION	
1	Unlimited	≤30 °C/85% RH	168 +5/-0	85 °C/85% RH	NA	NA	NA
2	1 year	≤30 °C/60% RH	168 +5/-0	85 °C/60% RH	NA	NA	NA
2a	4 weeks	≤30 °C/60% RH	696 ² +5/-0	30 °C/60% RH	120 +1/-0	168 +1/-0	60 °C/60% RH
3	168 hours	≤30 °C/60% RH	192 ² +5/-0	30 °C/60% RH	40 +1/-0	52 +1/-0	60 °C/60% RH
4	72 hours	≤30 °C/60% RH	96 ² +2/-0	30 °C/60% RH	20 +0.5/-0	24 +0.5/-0	60 °C/60% RH
5	48 hours	≤30 °C/60% RH	72 ² +2/-0	30 °C/60% RH	15 +0.5/-0	20 +0.5/-0	60 °C/60% RH
5a	24 hours	≤30 °C/60% RH	48 ² +2/-0	30 °C/60% RH	10 +0.5/-0	13 +0.5/-0	60 °C/60% RH
6	Time on Label (TOL)	≤30 °C/60% RH	TOL	30 °C/60% RH	NA	NA	NA

Figure 5-4: Moisture Sensitivity Level Chart

Please note that the modules **must receive solder-reflow 72 hours after pre-baking**. This maximum time is otherwise known as “Floor Life”. If the waiting time exceeds 72 hours, the module may be damaged (cracks / de-lamination, etc.) during the solder-reflow process due to excessive moisture pressure.

Drying

If the modules are exposed to high temperatures in the solder-reflow process, the moisture vapor pressure inside the modules will increase greatly. To prevent delamination, cracking, or “popcorn” effect” to the module, it may need to undergo the pre-baking procedure prior to any high-temperature or solder reflow process. The recommended baking time for the Sierra Wireless GNSS module is: 50°C for four hours, when humidity condition RF is about 30% ~ 50%.

Once baked, the module’s floor life will “reset”, which means the module will remain in normal factory condition for next 72 hours for solder-reflow process.

Note: the “Popcorn Effect” is when the IC/module “pops” because the moisture inside the package expands in the reflow process.

Important: Please limit the number of times that GNSS modules undergo the baking process. Repeated baking processes will affect performance of wetting on the SMD pad contacts. This applies to all SMT devices.

Important: Risk of Oxidation: Baking SMD packages may cause oxidation and/or inter-metallic growth of terminations, which if excessive, can result in problems of solderability during board assembly. The temperature and time for baking SMD packages are therefore limited by solderability considerations. The cumulative bake time at a temperature greater than 90°C and up to 125°C shall not exceed 96 hours. Bake temperatures higher than 125°C are not allowed.

ESD Handling

Warning: *Please follow the precautions addressed below carefully to prevent severe damage to GNSS modules.*

Sierra Wireless modules are sensitive to electrostatic discharges and thus are Electrostatic Sensitive Devices (ESD). Handle the GNSS modules particularly to its patch antenna (if included) and RF_IN pin carefully. Please follow the standard ESD safety practices stated below:

- Unless there is a galvanic coupling between the local GND and the PCB GND, then the first point of contact when handling the PCB shall always be between the local GND and PCB GND.
- Before working with the RF_IN pin, please make sure the GND is connected.
- When working with the RF_IN pin, do not contact any charged capacitors or materials that can easily develop or store charges such as the patch antenna, coax cable, or soldering iron.
- Please do not touch the mounted patch antenna, to prevent electrostatic discharge from the RF input
- When soldering RF_IN pin, please make sure to use an ESD safe soldering iron tip.

6: Reflow Soldering Temperature Profile

The following reflow temperature profile was evaluated by Sierra Wireless and has been proven to be reliable qualitatively. Please contact us beforehand if you plan to solder this component using a deviated temperature profile as it may cause significant damage to our module and your device.

All the information in this datasheet can only be used for a Pb-free manufacturing process.

SMT Reflow Soldering Temperature Profile (For Reference Only)

Average ramp-up rate (25 ~ 150°C): 3°C/sec. max.

Average ramp-up rate (270°C to peak): 3°C/sec. max.

Preheat: 175 ± 25°C, 60 ~ 120 seconds

Temperature maintained above 217°C: 60~150 seconds

Peak temperature: 250 +0/-5°C, 20~40 seconds

Ramp-down rate: 6°C/sec. max.

Time 25°C to peak temperature: 8 minutes max.

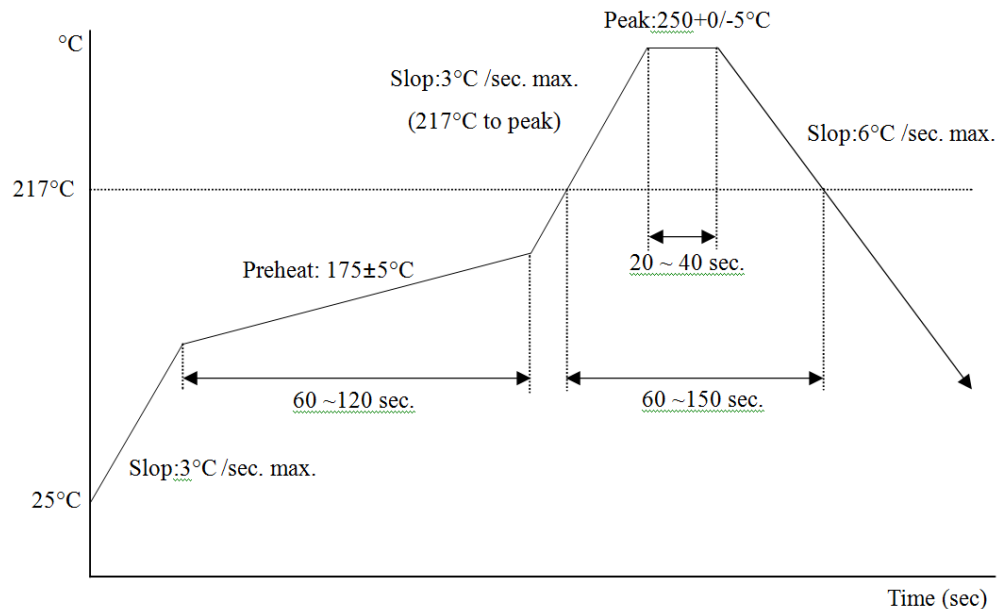

Figure 6-1: SMT Reflow Profile

Table 6-1: Procedures

	Description	Suggestions	Notes
1	Before proceeding with the reflow-soldering process, the GNSS modules might need to be pre-baked. Please refer to Conditions for Pre-baking .	Pre-bake Time: 4 Hours @ 50°C to 60°C.	The maximum tolerated temperature for the tray is 100°C. After pre-baking, make sure the temperature is cooled down to 35°C or below, to prevent tape and reel deformation.
2	PCBA (along with the patch antenna) is highly endothermic during the reflow-soldering process. Extra care must be paid to the GNSS module's solder joints if any signs of cold welding or false welding.	The parameters of the reflow temperature must be set accordingly to module's reflow-soldering temperature profile.	Double check to see if the surrounding components around the GNSS module are displaying symptoms of cold weld(ing) or false welding.
3	Special attentions to PCBA board are needed during the reflow-soldering process. See if the PCBA board is bended or deformed, possibly due to the weight of the module. If so, this will cause concerns at the latter half of the production process.	A loading carrier fixture must be used with PCBA if the reflow soldering process applies rail conveyors for the production.	If the PCBA board is bent or deformed, it may collide into one another during the unloading process.
4	Before the PCBA reflow-soldering process, the operator must check with their own eyes to see if there is a positional offset to the module, as it would be difficult to readjust after the module has gone through reflow-soldering process.	The operator must check with their own eyes and readjust the position before reflow-soldering process.	If the operator plans to readjust the module position, please do not touch the patch antenna while the module is hot in order to prevent a rotational offset between the patch antenna and module.
5	Before handling the PCBA, it must be cooled to 35°C or below after it has undergone a reflow-soldering process, in order to prevent a positional shift which may occur when the module is still hot.	1. One may use electric fans behind the reflow machine to cool them down. 2. Cooling the PCBA can prevent the module from shifting due to fluid effect.	It is very easy to cause a positional offset to the module and its patch antenna when handling the PCBA under high temperatures.

Table 6-1: Procedures

	Description	Suggestions	Notes
6	<p>1. When separating the PCBA panel into individual pieces using the V-Cut process, special attention is needed to ensure that there are sufficient gap between patch antennas.</p> <p>2. If V-Cut/cutting must be done manually, please make sure the operators are not using excessive force as that may cause a rotational offset to the patch antennas.</p>	<p>1. The blade and the patch antenna must have a distance gap greater than 0.6mm.</p> <p>2. Do not use the patch antenna as a leverage point when separating the panels by hand.</p>	<p>1. A test must first be performed to determine if the V-Cut process is going to be used. Ensure that there is enough space between the blade and the patch antenna so that they do not touch one another.</p> <p>2. An uneven amount of manual force applied to the separation will likely to cause a positional shift in the patch antenna and module.</p>
7	<p>When separating a panel into individual pieces during the latter half of the production process, special attention is needed to ensure the patch antennas do not come in contact with one another in order to prevent chipped corners or positional shifts.</p>	<p>Use a tray to separate the individual pieces.</p>	<p>It is possible to chip a corner and/or cause a shift in position if patch antennas come in contact with each other.</p>

Other Cautionary Notes on the Reflow-Soldering Process:

1. The module may need pre-baking before going through the SMT solder reflow process. Please refer to [Conditions for Pre-baking](#).
2. The usage of solder paste should follow the “FIFO (First-in-First-out)” principle. Opened solder paste needs to be monitored and recorded in a timely manner (please refer to IPQC standards for related documentation and examples).
3. Temperature and humidity must be controlled within an SMT production line and storage area. A temperature of 23°C, 60±5% RH humidity is recommended (please refer to IPQC standards for related documentation and examples).
4. When performing solder paste printing, please notice if the amount of solder paste is excessive or insufficient, as both conditions may lead to defects such as electrical shortage, empty solder, and etc.
5. Make sure the vacuum mouthpiece is able to bear the weight of the GNSS module to prevent positional shift during the loading process.
6. Before the PCBA goes through the reflow-soldering process, the operator must visually check if there is a positional offset to the module.
7. The reflow temperature and its profile data must be measured before the SMT process and match the levels and guidelines set by IPQC.
8. If the SMT protection line is running a double-sided process for PCBA, please process the GNSS module during the second pass only to avoid repeated reflow exposures of the GNSS module. Please contact Sierra Wireless beforehand if you must process the GNSS module during the first pass of a double-side process.

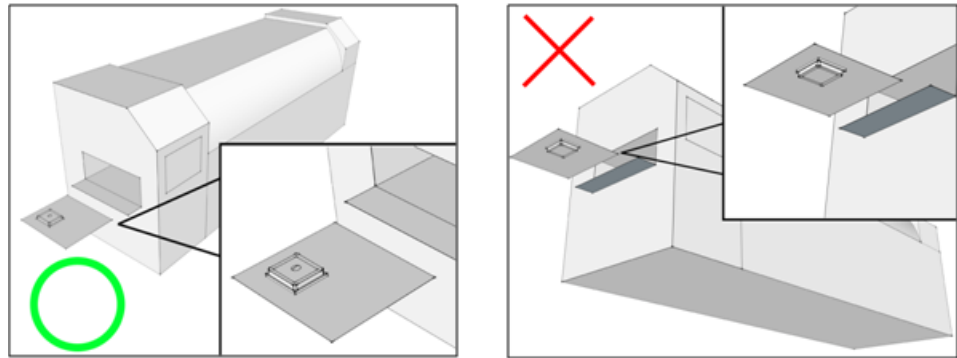

Figure 6-2: Place the GNSS module top side up when running the reflow-solder process. Do not invert.

Manual Soldering

Soldering iron:

Heat temperature: under 380°C | Time: under three seconds.

Notes:

1. To prevent further oxidation, do not touch the soldering pads on the surface of the PCB board directly.
2. The solder paste must be defrosted to room temperature before use so it can return to its optimal working temperature. The time required for this procedure is unique and dependent on the properties of the solder paste used.
3. The steel plate must be properly assessed before and after use, so its measurement stays strictly within the specification set by the SOP.
4. Be cautious to the spacing between soldering joints, as excessive soldering may cause electrical shortages.
5. To avoid possible siphon effects on neighboring components which may lead to electrical shortage, do not use an extensive amount of flux.
6. Do not use the heat gun for long periods of time when removing the shielding or inner components of the GNSS module, as it is very likely to cause a shift to the inner components and will lead to electrical shortages.